

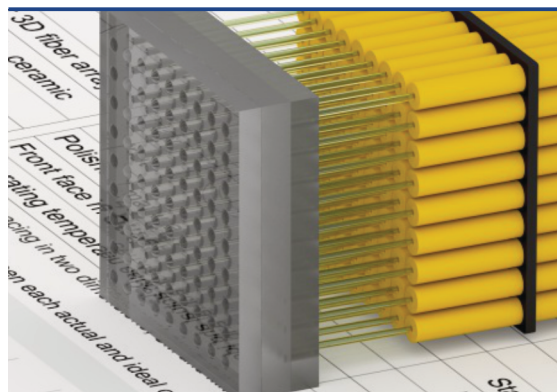

# Fiber Coupled Microlens Array

## 2D Fiber Array Actively Aligned onto MLA



The manufacture of high-precision customized 2D fiber arrays together with MLA active alignment enables us to offer customized MLAs of high number functional channels with minimum deviating angle error of outgoing light rays.

A choice of suitable MLA is based on the customer requirement for a shape of outgoing light rays, type of fiber and the operating wavelength. The other end of fibers can be connectorized by E2000, LC, SC, FC, ST or by MTP® connectors. MLA with pre-determined fiber length can be housed in a stainless steel flange for easier implementation within targeted application.

Highlights: Active alignment of optical fibers onto micro-lens array / Minimum tilt of light beam / High accuracy in light beam positioning / Customized fiber layout matrix / fiber types include SM, PM, MM (STEP/GRIN) / Availability of customized MLA housing.

**Applications:** Optical switching, imaging, sensor systems.

MLA Properties	Single Mode and Multi Mode Version	Polarization Maintaining Version
Size [mm]	12 x 12	12 x 12
Lens arrangement	m × n, hexagonal grid or others	m × n, hexagonal grid or others
Fiber type	MM (Step index or Graded index) SM (ITU-T G.652d, G.657a, b)	PM fibers (UV/VIS/NIR)
Angle misalignment [°]	-	± 1.5 or ± 2.5
Extinction ratio [dB]	-	20, 25, 30
Fiber array / MLA material	Borosilicate glass, fused silica / fused silica, BK7	Borosilicate glass, fused silica / fused silica, BK7
Output connectors	E2000, LC, SC, FC, ST, MTP®	E2000, LC, SC, FC, ST, MTP®
Operating temperature [°C]	-40 to +85	-20 to +70
Beam Properties	Values	We will propose a solution for you based on the required parameters of the output light beam from the MLA. For the calculation, we need to know following parameters: <ul style="list-style-type: none"> <li>operating wavelength</li> <li>fiber type</li> <li>working distance</li> <li>beam width</li> </ul>
Wavelength [nm]	850, 980, 1310, 1550 or on request	
Working distance [mm]	Typ. 25 or on request	
Insertion loss [dB]	Typ. 1	
Return loss [dB]	> 50	
Pointing accuracy [°]	Typ. < 0.2	
Beam width [μm]	Typ. 300 or on request	

### Fiber Coupled Microlens Array

### View A

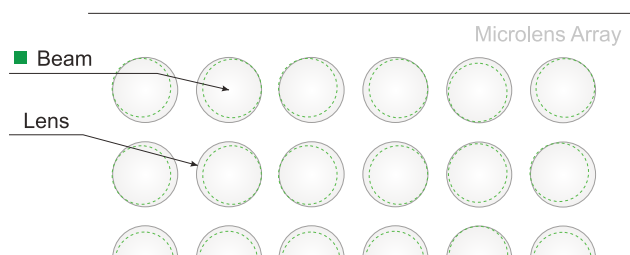
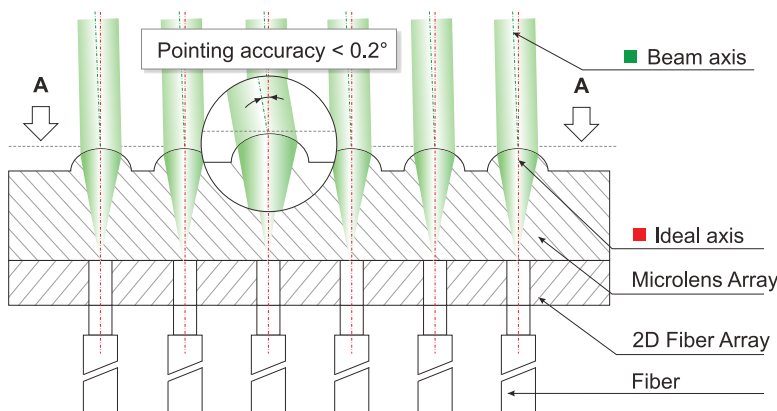

Due to the precise active fiber alignment onto the matrix of aspheric lenses we can guarantee minimum insertion losses for all channels, minimum tilts and offsets of outgoing light beams. The production method as well as additional antireflection broadband coating ensure minimum losses due to reflections. The high-power variant is available upon request.

### Fiber Coupled Microlens Array

